

Captive Screw Panel Fastener TR-PFHV

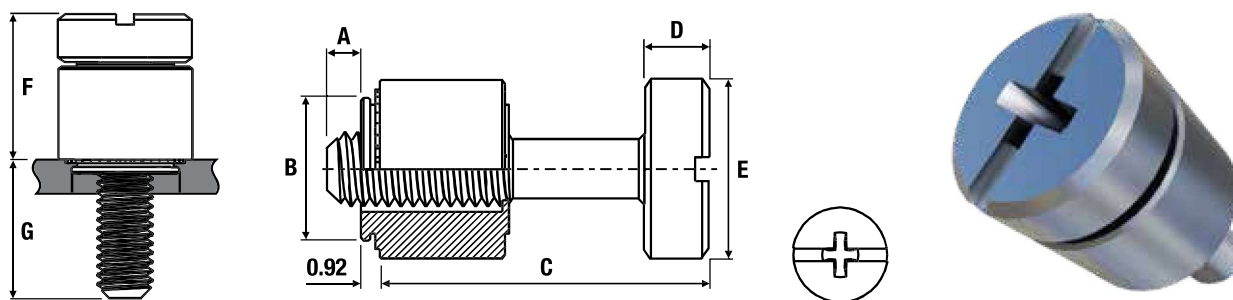

Metric Dimensions

Zinc Plated Steel: TR-PFHV

Thread	M3		M3.5		M4	
Screw code	0	1	0	1	0	1
A (shank) max.	0	1.9	0	2.30	0	2.7
B max.	5.49		5.98		6.38	
C nom.	11.25		12.47		14.1	
D ± 0.13	2.03		2.34		2.79	
E ± 0.25	6.95		7.45		7.85	
F nom.	6.69		7.45		8.5	
G ± 0.64	5.55	7.56	6.01	8.42	6.59	9.39
Min. sheet thickness	0.92		0.92		0.92	
Recommended hole size +0.08	5.5 - 5.58		6.0 - 6.08		6.4 - 6.48	
Min. distance to edge of sheet	5.8		6.3		6.7	

Metric Performance Data

Thread	M3	M3.5	M4
Test sheet material	Steel		
Installation (kN)	10.5	11.4	12.1
Push-out (N)	564	614	656

TR-PFHV - Recommended for use in sheet hardness: HRB 60 or less

