

Close To Edge Standoff TR-DSO/TR-DSOS

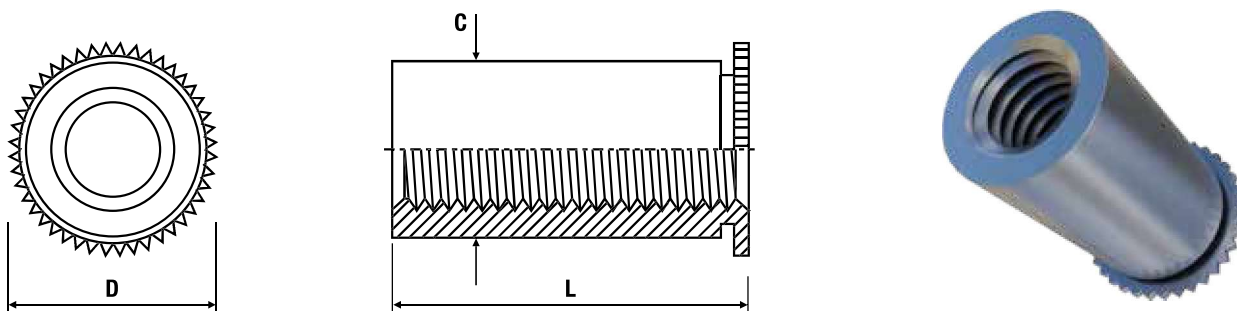

Metric Dimensions

Zinc Plated Steel: TR-DSO | Stainless Steel: TR-DSOS

Thread	M3	
(L) Length +0.05 -0.13	6.35	7.0
C max.	4.2	
D nom.	4.92	
Sheet thickness	0.94 - 6.35	
Recommended hole size +0.08	4.2	
Min. distance to edge of sheet	3.2	

Metric Performance Data

Thread	M3
Test sheet material	Steel
Installation (kN)	5.85
Push-out (N)	334
Torque-out (Nm)	1.2

TR-DSO - Recommended for use in sheet hardness: HRB 80 or less
 TR-DSOS - Recommended for use in sheet hardness: HRB 70 or less

