

# Nylon Insert Broaching Nut TR-CFN

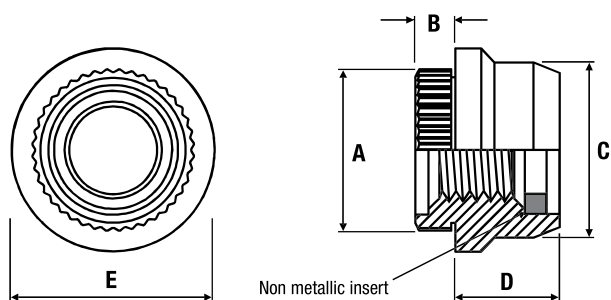

## Metric Dimensions

Stainless Steel: TR-CFN

Thread	<b>M3</b>
A	4.11
B	1.02
C	4.45
D	2.65
E max.	5.19
Min. sheet thickness	1.1
Recommended hole size +0.08	3.8
Min. distance to edge of sheet	2.93

## Metric Performance Data

Thread	<b>M3</b>
Test sheet material	Steel
Installation (kN)	4.45
Push-out (N)	44.5
Torque-out (Nm)	0.45

TR-CFN - Recommended for use in sheet hardness: HRB 60 or less

